

MEAT, DELI, CHEESE CASE - ATM

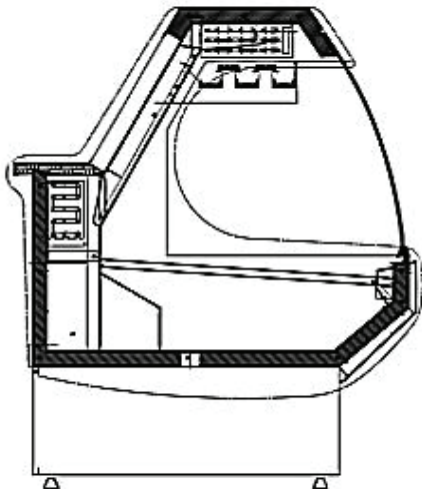

Top and Side Gravity Coil Refrigeration System

MODEL	DIMENSIONS	CAPACITY	VOLTAGE
ATM-1200	L52"XD45"xH51"	1/2HP	115V/8A/60Hz
ATM-1800	L76"XD45"xH51"	2x3/8HP	115V/15A/60Hz
ATM-2400	L100"XD45"xH51"	2x1/2HP	115V/20A/60Hz

Standard:

- Curved front glass open from the top
- Tempered front glass
- S/S finished interior
- ABS gray sides
- Automatic defrosting
- Automatic condensation disposal
- Interior LED lighting
- Front window defogger
- Environment friendly R 134
- Double duty complete with refrigerated bottom storage
- Drain system included and ready to be connected

Optional:

- Self contained
- Dry (non refrigerated) cases

Environment:

• The equipment is designed to operate under normal environmental conditions being below 75°F / 24°C ambient, 55% Relative Humidity.

- All measurements are approximates
- Specification is subject to change without notice

